

MICRO-CAP 10

Analog/Digital Simulator

INDUSTRIAL-STRENGTH SIMULATION



spectrum



Micro-Cap 10... Ten Generations of Refinement in Circuit Simulation

Micro-Cap 10 is an integrated schematic editor and mixed analog / digital simulator that provides an interactive sketch and simulate environment for electronics engineers. It has seen ten generations of refinement since its release in 1982. It blends a modern, intuitive interface with robust numerical algorithms to produce unparalleled levels of simulation power and ease of use.

Fast

Algorithmic improvements, optimized code, and an integrated interface contribute to the stunning speed of Micro-Cap 10.

Powerful

Numerous features contribute to the power of Micro-Cap 10:

- Multi-page hierarchical schematic editor
- PSpice™, SPICE3, and many HSPICE™ commands and models supported
- Threading support for multiple CPUs and faster simulations
- Native digital simulation engine
- Periodic Steady State analysis
- Integral circuit optimizer with multiple optimization methods
- Harmonic and intermodulation distortion analysis
- Integrated active and passive filter design function
- Device library with over 24,000 parts
- Analog and digital behavioral modeling
- Schematic waveform probing
- On-schematic voltage/state, current, power, and condition display
- Dynamic analysis updates waveforms and curves as you edit
- During the run plotting
- Smith charts / polar plots
- Multidimensional parameter stepping
- Monte Carlo analysis
- 3D plotting
- Performance functions and plots
- Optimizing parts modeler
- Gummel-Poon, Mextram and Modella bipolar models
- Berkeley BSIM1, BSIM2, BSIM3, and BSIM4 MOSFET models
- The latest Philips device models, including MOS 11, 20, 31, 40, and PSP 102
- EKV V2.6 MOSFET model
- Hefner IGBT model
- IBIS model translator
- Animated LEDs, switches, bars, meters, relays, stoplights, and DC motors
- Sample and hold, timer, and Z transform devices
- Lossy transmission lines
- Jiles-Atherton nonlinear magnetics model
- PCB interface to popular packages
- LAN version for collaborative projects

Easy to use

The graphical, user-friendly interface is simple to learn and use. Familiar SPICE models, plus extensions, are easy to apply. Over 500 warnings and messages help you through problems, when the error occurs, not later in a text file.

Affordable

You can easily spend two to five times the cost of Micro-Cap 10 for other simulators without matching its power, speed, and ease of use.

Guaranteed

Micro-Cap 10 comes with a full, unconditional, 30 day money-back guarantee.

PRINCIPAL FEATURES

Integrated schematic editor and simulator

The multi-page hierarchical schematic editor makes it easy to sketch a circuit. Once a circuit is created, you can do transient, AC, DC, transfer function, harmonic or intermodulation distortion, or sensitivity analysis. The schematic editor features stepping, scaling, panning, multiple-object selection, three axes rotation, mirroring, drag copying, and clipboard functions, with multistage undo and redo. Probe the schematic with the mouse to display curves and waveforms, or use Dynamic Analysis mode to see waveforms change as you edit the circuit.

SPICE compatible models and simulator

Micro-Cap reads, writes, creates, and analyzes standard SPICE text files as well as its own schematic files. You can use the schematic editor to create schematics or the text editor to build SPICE text file circuits. Micro-Cap can analyze either format and can use text file subcircuit models in schematics. Micro-Cap also creates SPICE files from its own schematics.

Native digital simulator

The internal 5-state, event-driven digital simulator lets you run digital or mixed mode simulations using your own models or those from our extensive digital library.

Active and passive filter designer

The active filter designer creates low pass, high pass, band pass, notch, and delay filters with Bessel, Butterworth, Chebyshev, inverse-Chebyshev, or elliptic responses in both polynomial and schematic form. Individual stages can be chosen from many topologies, including Sallen-Key, MFB, Tow Thomas, Fleischer-Tow, KHN, and Acker-Mossberg. The passive filter designer creates low pass, high pass, band pass, and notch filters with Butterworth, Chebyshev, or elliptic responses in several circuit configurations.

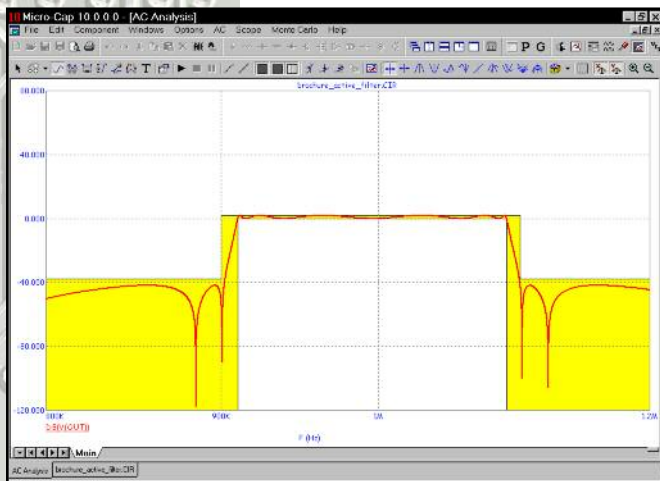
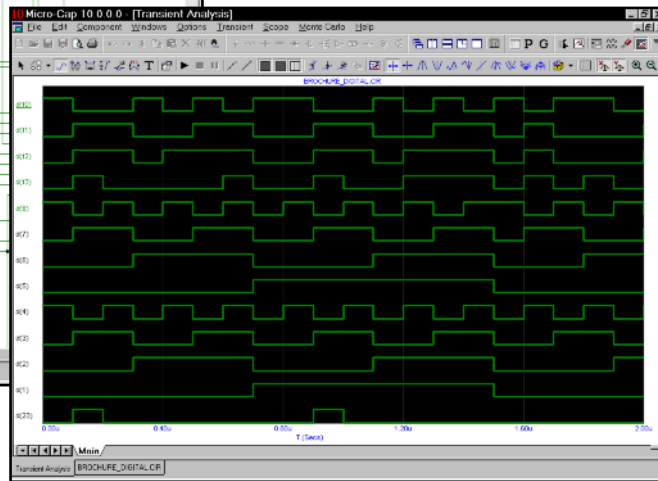
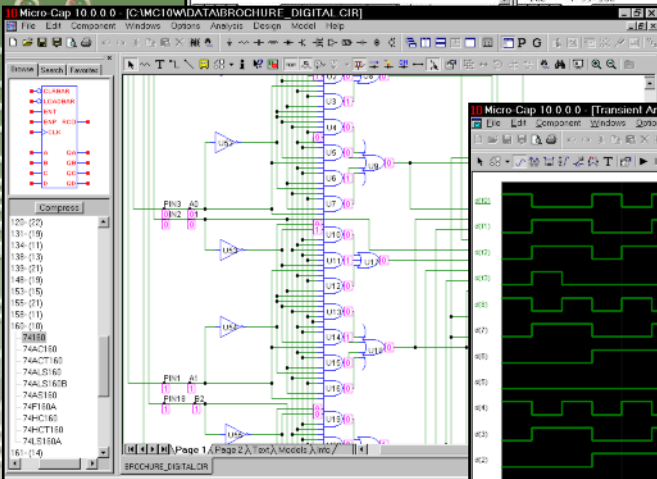
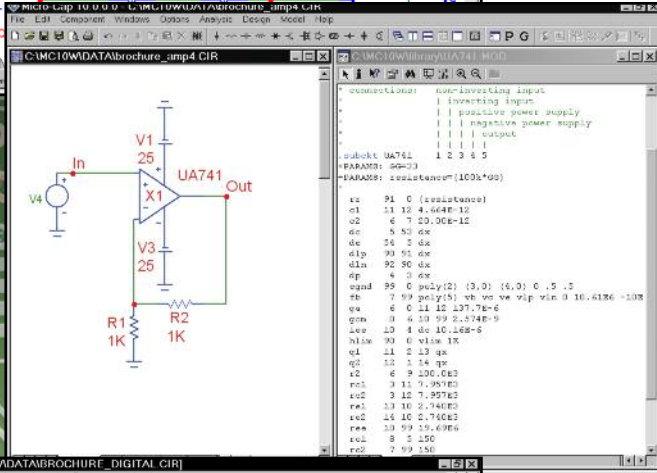
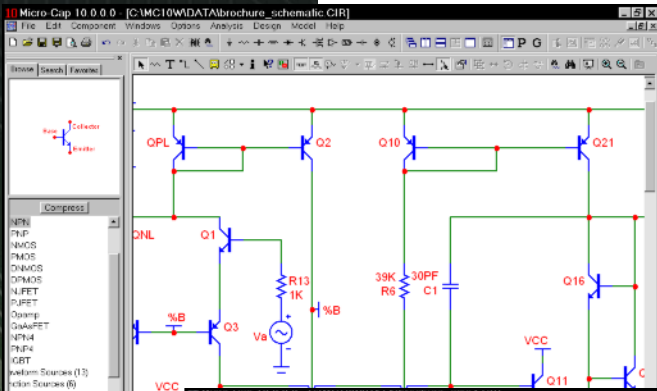

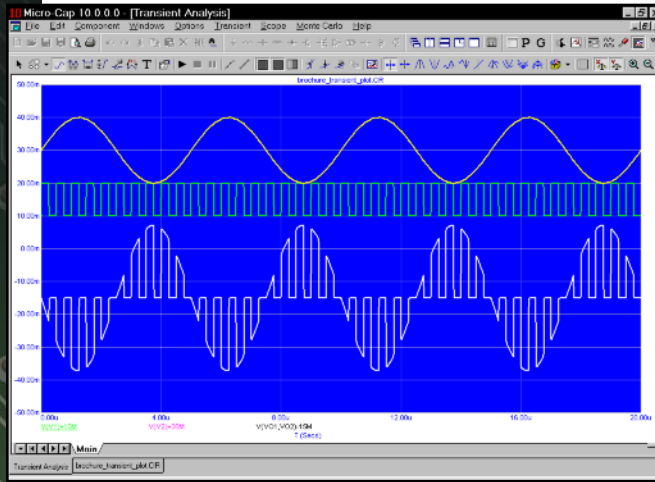

ANALYSIS

Transient analysis-for time-domain waveforms

You can plot digital state, voltage, current, power, energy, charge, capacitance, inductance, B field, and H field. A variety of variables and mathematical functions simplify plots. A new Periodic Steady State option eliminates transients.

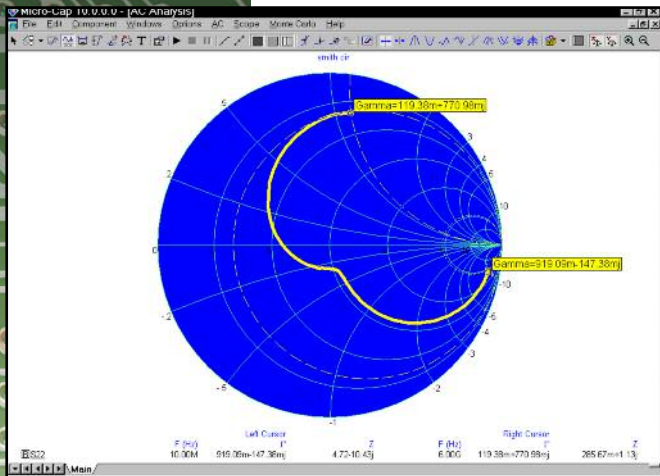

AC analysis-for small signal behavior

With AC analysis you can plot voltage or current and produce Bode plots, Nyquist diagrams, Nichols charts, Smith charts, polar plots, and noise. Real, imaginary, magnitude, phase, and group delay operators make analysis and plotting easy.

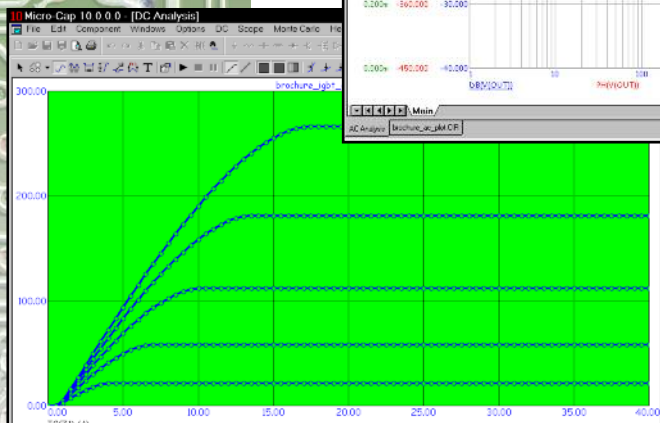
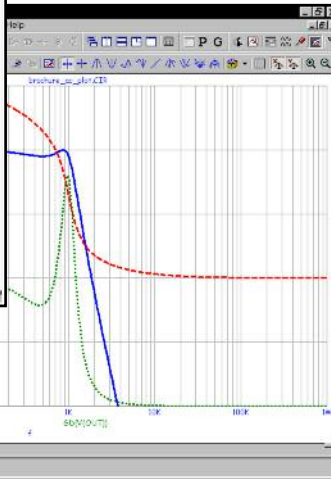

DC analysis-for DC behavior

You can use DC analysis for various plots, including transfer functions, where one source is varied, and device IV curves, where two sources are varied. Transfer function plots help to determine DC offset, bias, and overall amplifier DC gain.

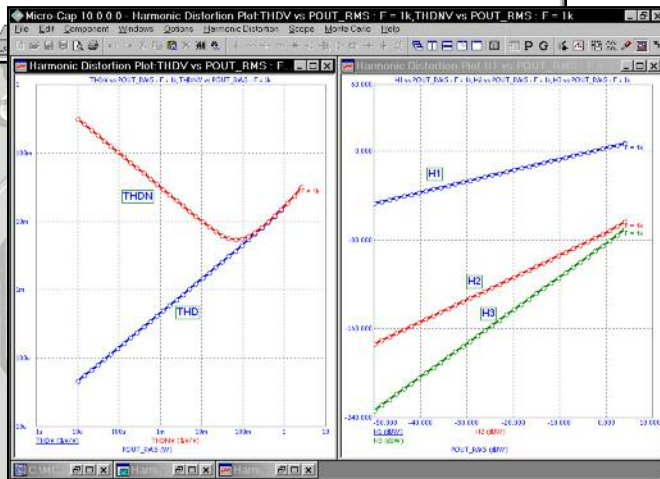

Distortion analysis

Harmonic distortion analysis creates plots of THD, THDN, SINAD, SNR, and Hn. Intermodulation distortion analysis creates plots of H1, IM2, and IM3. Any of these can be plotted vs. F, VIN, VOUT, PIN, and POUT. Supports both audio and RF applications. Accurate harmonics are assured with the new Periodic Steady State feature.

DESIGN OPTIMIZATION

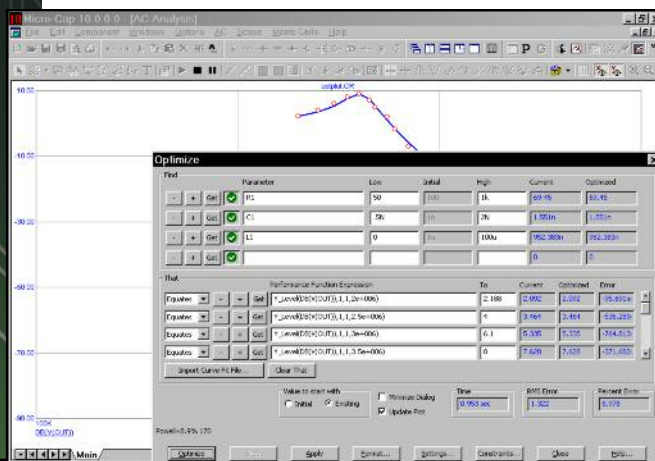

Optimizer-for fine tuning designs

The integral optimizer tunes parameters to maximize any performance function or to fit any curve, handling many kinds of design optimization problems. Four optimization algorithms, Powell, Hooke-Jeeves, Levenberg-Marquardt, and Differential Evolution, provide power and flexibility to solve the toughest problems.

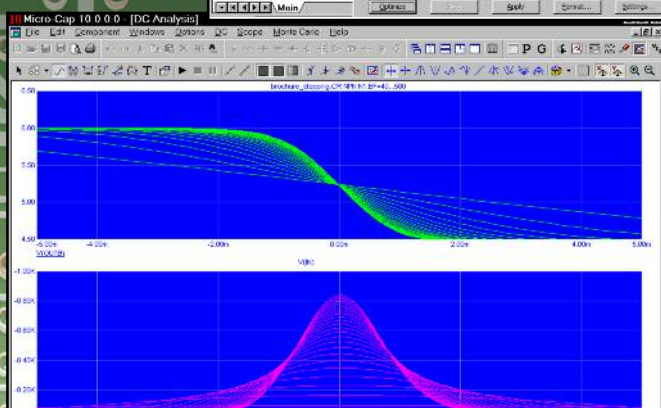

Parameter stepping- for parameter dependence

Step parameters to see how circuit behavior is affected. Try different designs, explore design limits, and tailor performance. You can step linearly, logarithmically, or from a list. With list stepping, you can even step text names. This is useful for stepping through different model statement or subcircuit names.

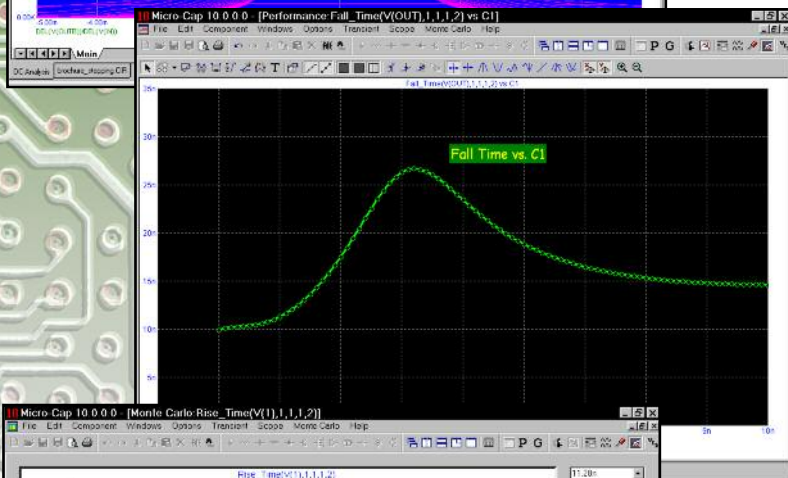

Performance Plots-for parameter sensitivity

You can directly measure and plot performance characteristics versus circuit parameters. Performance parameters include rise time, fall time, pulse width, frequency, period, peak, bandwidth, phase and gain margin, and many more.

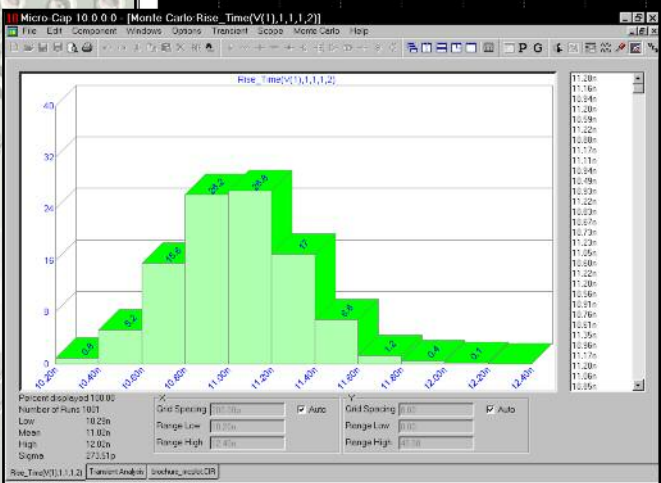

Monte Carlo-for design centering

Monte Carlo routines construct hundreds of circuits, each containing parts with parameters picked from distributions you choose. This helps identify circuit problems and improves production yield. You can use both absolute and relative tolerances and worst case, Gaussian, or uniform distributions. Results are generated in both numeric and histogram form for easy inspection and review.

MODELING

Analog behavioral modeling-what if analysis

Analog behavioral modeling-for system level simulation. Laplace sources let you describe the S-plane linear transfer function of a circuit block. Function sources let you model instantaneous nonlinear behavior. The source can be a mathematical function of any other circuit variable, such as a node voltage or a device current.

Expressions can also be used for resistor, capacitor, and inductor values. Here are some sample expressions:

$G*b0/(s^2+b1*s+b0)$
 $-k*(v(p)-v(c)+u*(v(g)-v(c)))^1.5$
 $VZ+tempco*(TEMP-28)$
 $Sin(2*pi*T)*Exp(-T)$

Low pass filter
Triode
Reference source
Damped sine wave

MODEL-rapid creation of optimized device models

If you can't find what you need in our huge library, you can use MODEL, to produce optimized model parameters from data sheet values or graphs.

Nonlinear magnetics model

The Jiles-Atherton magnetics model lets you analyze nonlinear behavior of cores, reactors, and transformers. You can plot the current, voltage, flux, inductance, and B and H fields. The parts library includes models for hundreds of commercial devices.

IBIS translator

Micro-Cap 10 translates IBIS models into SPICE models which accurately reproduce the IBIS Golden Waveforms.

Advanced MOSFET models

Micro-Cap 10 includes the EKV 2.6 and four BSIM models, BSIM1, BSIM2, BSIM3v3.3, and BSIM4.5.0 for advanced work with short channel devices. Short-distance matching and binning are provided for advanced modeling.

Advanced bipolar models

In addition to the standard Gummel-Poon model, Micro-Cap offers the Modella and Mextram for advanced simulation of bipolar devices.

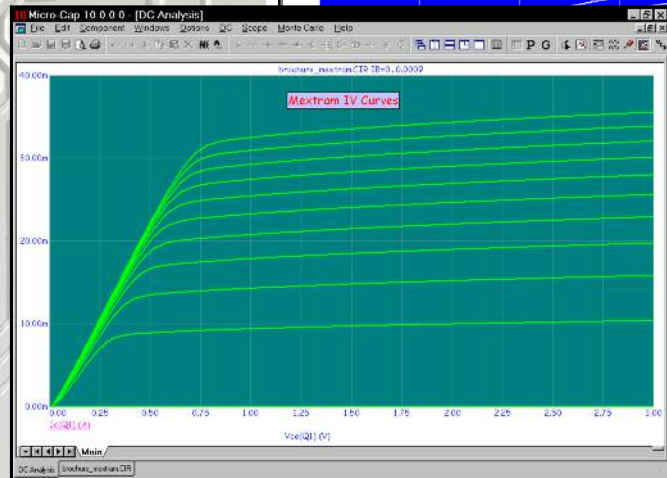
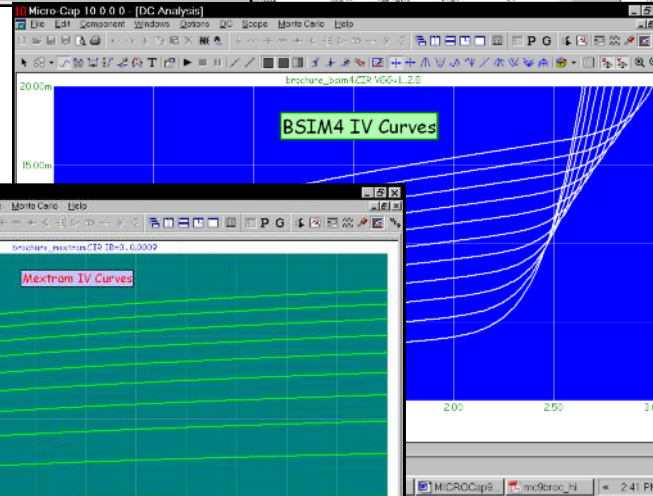
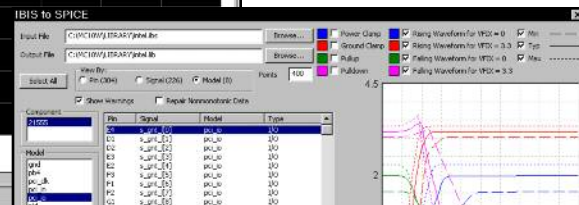
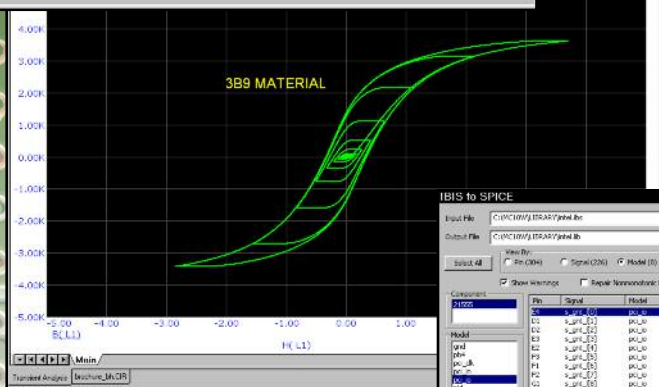
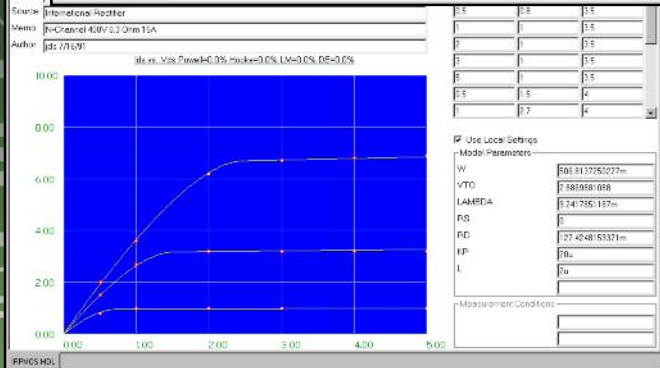
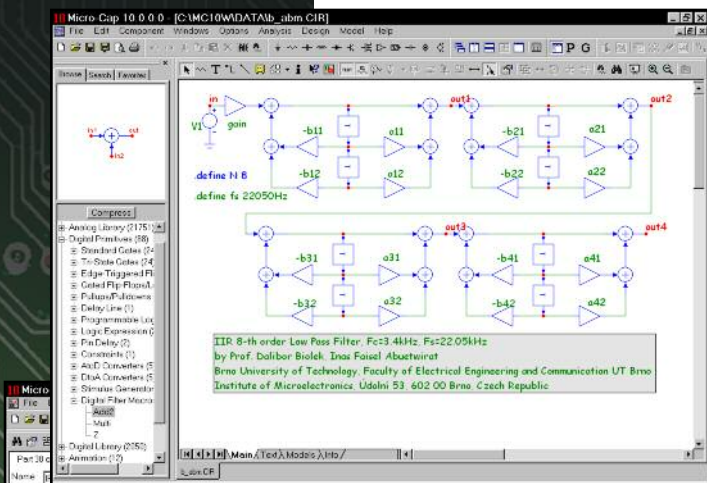

DISPLAY AND PLOTTING

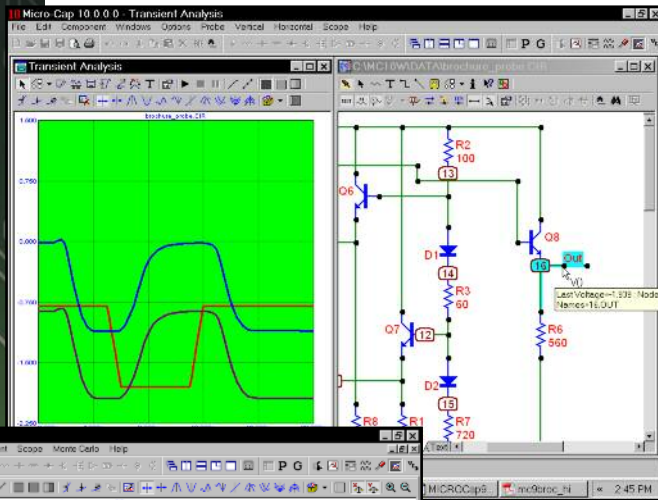

Direct schematic waveform probing

MC10 lets you probe circuits directly for waveforms. Simply point the mouse at a device or circuit node and click. You can measure digital states, voltage, current, power, energy, charge, capacitance, flux, inductance, B field, or H field. The probe can display transient, AC, or DC analysis results. It's like probing a circuit with a scope, a spectrum analyzer, or a curve tracer.

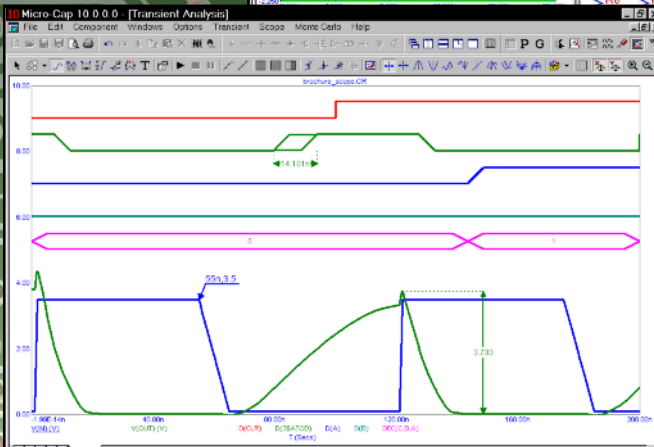

Scope-easy review of waveforms

This feature lets you zoom, pan, size, scale, tag data points, inspect values, and use performance functions to analyze waveforms and curves. Scope lets you magnify a waveform, read out its value, check its slope, find a peak, compare it to another waveform, or measure its rise time, fall time, width, period, frequency, peak-to-peak value, and many other performance-related criteria. You can annotate the plot with text and add graphics and numeric tags that show the X and Y values at individual data points or between two data points.

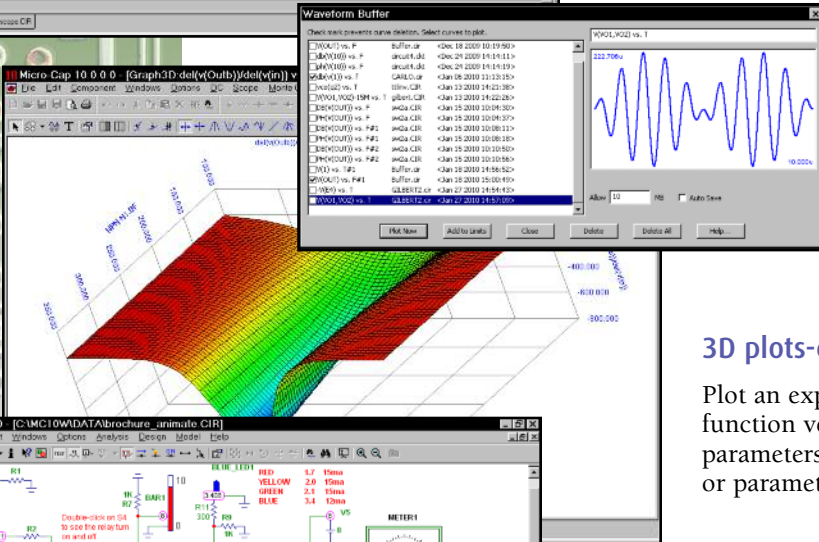

Waveform Buffer

This feature saves curves and waveforms for future analysis, display, and comparison. Curves can be saved manually or automatically up to a specified memory limit.

3D plots-design visualization

Plot an expression or performance function versus any two stepped parameters to show temperature or parameter effects.

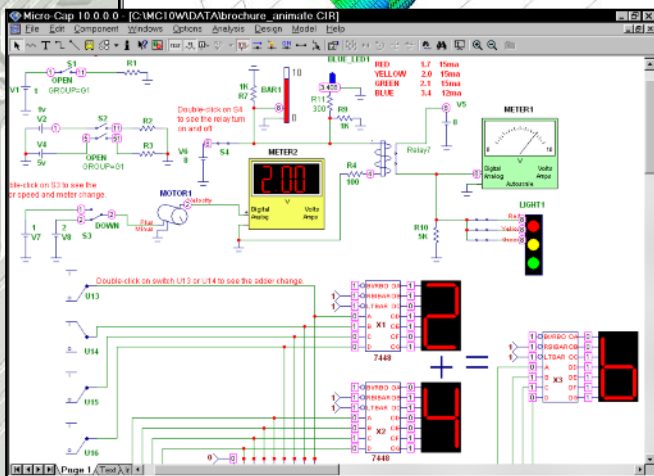

ADDITIONAL FEATURES

Animated devices-visualization and interaction

Seven segment displays, LEDs, switches, bars, meters, relays, stoplights, and DC motors provide visualization and interaction. Mouse clicks open and close switches, meters read DC voltage and current, relays open and close, seven segment displays respond to digital input states.

Large device library

With over 24,000 parts in the device model library, you'll be able to quickly find most digital parts, and analog parts like diodes, MOSFETs, BJTs, OPAMPs, IGBTs, JFETs, magnetic cores, crystals, and SCRs.

Waveform import capability

This feature lets you import waveforms from SPICE or Micro-Cap 10 output files for direct comparison. You can also use the difa() and difd() functions to automatically compare two analog or digital waveforms. They report differences between the waveforms, simplifying testing.

Extensive mathematical operators and variables

Operators include arithmetic, trigonometric, hyperbolic, Boolean, relational, integration, differentiation, and FFT or signal processing types. You can even do Bessel functions and infinite series expressions. Variables include voltage, current, power, energy, charge, flux, capacitance, resistance, inductance, B field, and H field. Device variables include lead currents and lead-to-lead voltages, such as base current and base-emitter voltage of an NPN.

Analog Primitives

- Battery voltage source
- Voltage source (SPICE format)
- Current source (SPICE format)
- Pulse voltage source
- Sine voltage source
- User-defined file source
- Resistor
- Capacitor
- Inductor
- Diode
- SPICE E, F, G, H sources
- Linear dependent two port source
- Transmission line (lossy or ideal)
- Transformer
- K device (magnetic coupling)
- Bipolar junction transistor (3 types)
 - Gummel-Poon
 - Mextram
 - Modella
- MOSFET models (13 types)
 - Original levels 1, 2, and 3
 - BSIM, BSIM2, BSIM3v3.3, BSIM4.5.0
 - EKV V2.6
 - Philips MOS 11, 20, 31, 40, and PSP 102
- Hefner IGBT model
- OPAMP
- GaAsFET (3 models)
- JFET

- Analog behavioral sources
 - Laplace function (S-domain expressions)
 - Laplace table (S-domain tabular functions)
 - Function (Time-domain algebraic expressions)
 - Table (Time-domain tabular functions)
- Z transform source
- Sample and hold source
- S-Y-Z-H-G-T-ABCD parameter
 - N-port model
- Switches (3 types)
- Timer function block
- Macro blocks
 - Absolute value
 - Amplifier
 - Center-tapped transformer
 - Clip function
 - Comparator
 - Crystal
 - Delay
 - DIAC
 - Differentiator
 - Digital potentiometer
 - Divider
 - F(s) Laplace block
 - Frequency shift keyer
 - Gyrator
 - Ideal transformer 2 port
 - Ideal transformer 3 port
 - Integrator
 - Multiplier
 - Noise source
 - Phase shift keyer
 - Potentiometer
 - Programmable unijunction transistor
 - Pulse width modulator
 - Relay
 - Resonant tank circuit
 - Schmitt trigger
 - Silicon-controlled rectifier
 - Slip circuit
 - Snubber diode
 - Spark gap
 - Subtractor
 - Summer (two input)
 - Summer (three input)
 - Triac
 - Triode
 - Voltage-controlled oscillator
 - Wideband transformer

Digital primitives

- Standard and tri-state gates
 - Buffer
 - Inverter
 - And
 - Or
 - Nand
 - Nor
 - Xor
 - NXor
- Edge-triggered flip-flops
 - JK type
 - D type

- Gated flip-flops and latches
 - SR
 - Latch
- Digital loads
 - Pullup
 - Pulldown
- Delay line
- Programmable logic array
- Analog to digital converter
- Digital to analog converter
- Analog to digital interface
- Digital to analog interface
- Digital behavioral modeling
 - Logic expression
 - Pin delay
 - Constraint checker
- Stimulus generators

Animated primitives

These versatile devices use motion and color to indicate state behavior and respond to mouse clicks.

- Analog / digital voltmeter/ammeter
- Analog color LED
- Analog color bar
- DC Motor
- Digital LED
- Digital switch
- SPDT, SPST, DPST switches
- Relay
- Seven segment display
- Traffic light

Extensive help system

- Over 20,000 lines of on-line help is context sensitive, indexed, and topically arranged for easy learning.
- Over 500 error messages help you pinpoint circuit problems. Most error messages come with a "More" button for additional description of the nature of the problem.
- Over 200 sample circuits give you plenty of examples to learn design and simulation techniques.
- Over 100 Help Bar notes describe program features as you move the mouse over them.
- Over 20 live demos illustrate the workings of the program.



Spectrum Software

1021 South Wolfe Road
Sunnyvale, CA 94086
Tel: 408-738-4387
FAX: 408-738-4702
Internet: www.spectrum-soft.com
Support: support@spectrum-soft.com
Sales: sales@spectrum-soft.com